

PT100, PT500 and PT1000 temperature sensors are used for high precision measuring and monitoring of temperatures in e.g. motor bearings, machine components, windings in electric, motors, generators and transformers.

The linear resistance/temperature function simplifies many electronic applications.

PT100, PT500 and PT1000 are available in 2, 3 and 4-wire circuit versions for various requirements of metrological precision.

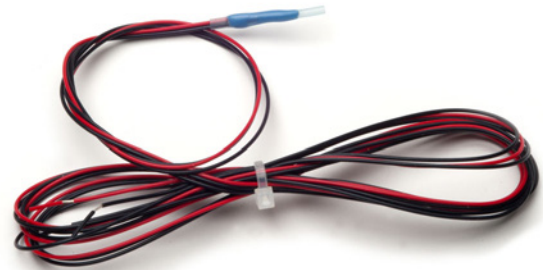

PT 100/500/1000 temperature sensors

## Typical applications

The sensor's precision allows it to be used for a variety of applications where temperature monitoring with limit switch functions are required. The PT100, PT500 and PT1000 sensors are therefore frequently used in the process industry where controlled operations without interruptions are essential.

Typical applications are temperature monitoring of motor bearings, machine components, windings in electric motors, generators, transformers, pump installations and basically most installations requiring temperature monitoring.

## Properties

- Very exact temperature measuring with a precision accuracy of  $\pm 0.5^{\circ}\text{C}$ .
- Measurement over a wide temperature range.
- Good linearity of the temperature/resistance characteristic curve (values comply with DIN 60751, see table in technical data)
- Small dimensions/low weight.
- Short response time.
- Good resistance to vibrations.

## Description/function

The PT sensors are produced on a ceramic base chip with a thin film laser structured platinum layer functioning as a temperature dependent component. The sensor's resistance increases linearly with the temperature.

The sensor is available in several versions PT100, PT500 and PT1000. The function is identical but the resistance varies between the types. Our standard is the PT100 sensor with a tolerance class complying with DIN Class B (resistance and tolerances can be found in the technical data).

## Versions

The PT100 sensor (compliant with DIN Class B) is our standard and a number of different versions are stocked (see item list). The compact format allows the sensor to be mounted mechanically in a variety of designs ranging from standard versions to unique project executions.

The sensor is available in 2, 3 and 4-wire circuit versions for various requirements of metrological precision (see diagram). Wiring is selected according to the specific data and application requirements in terms of mechanics and temperature.

PT500 and PT1000 sensors are available on request.

## Examples of variants

- Minimal size heat shrink tubing for mounting in windings, etc.
- Threaded version for installation in motor bearings, etc.
- Mounted in ring cable shoes for screw attachment to the heat sink, etc.
- Mounted in metal tubing (steel, brass, ceramic) for plug-in installation and temperature measurement of bearing housings, etc.
- Integrated in "dip sticks" for temperature measurement of engine/generator traces, from one to several measuring points along the length of the stick.

## Technical data

Electrical data	
Nominal resistance:	100 Ω at 0°C (PT 100)
Basic thermistor values:	For platinum measuring resistors, as in chart
Measuring range:	-50°C to +230°C, other ranges on request
Recommended applied current:	1mA PT 100, 0,5mA PT 500, 0,3mA PT 1000 (Self-heating must be considered.)
Circuit:	Standard: 2-wire, On request: 3-wire or 4-wire circuit
Insulation strength:	2.5 kV, on request up to 8 kV

Mechanical data		
Type:	PT-sensor for surface measuring Alu-housing screw-in sensor SW 10/ M4 ring shaped cable eye for self- tapping sheet metal screw	PT-sensor for winding monitoring e.g.: electric motors, transformers: in stabilised shrink tube design
Lead-in:	AWG 24, CU-strand silvered, Teflon insulation (optional: AWG 26, Cu-strand silvered, Teflon insulation, shielded cable) Standard colour: red/white, Standard length: 500mm ±1%	
Insulation class:	H	
Remarks:	Special designs for liquid or gaseous media, in V2A or other materials are ma- nufactured on request for customers specific applications and specification, also for PT 500, PT 1000 thermistors.	
Order specification:	Resistor thermometer as: 2-wire, 3-wire or 4-wire circuits	

**Characteristic temperature curves**

All sensors conform to DIN EN 60751:

-50 ... 0°C:  $R(t) = R(0) * (1 + A * t + B * t^2 + C * [t - 100] * t^3)$

0 ... 600°C:  $R(t) = R(0) * (1 + A * t + B * t^2)$

$A = 3.90802 * 10^{-3}$ ;  $B = -5.802 * 10^{-7}$ ;  $C = -4.2735 * 10^{-12}$

R(0) = thermistor value in Ohms at 0°C

**Classes**

The temperature sensors are available in the following classes:

1/3 DIN class B+  $\pm (0,10 + 0,0017 * t)$

1/3 DIN class B-  $\pm (0,10 + 0,0050 * t)$

DIN class A  $\pm (0,15 + 0,0020 * t)$

DIN class B  $\pm (0,30 + 0,0050 * t)$

2 DIN class B  $\pm (0,60 + 0,0050 * t)$

t = absolute value of temperature in °C

Special versions are available on request.

Permissible deviation according to DIN EN 60751:

- DIN class A
- DIN class B
- 1/3 DIN class B-
- 1/3 DIN class B+

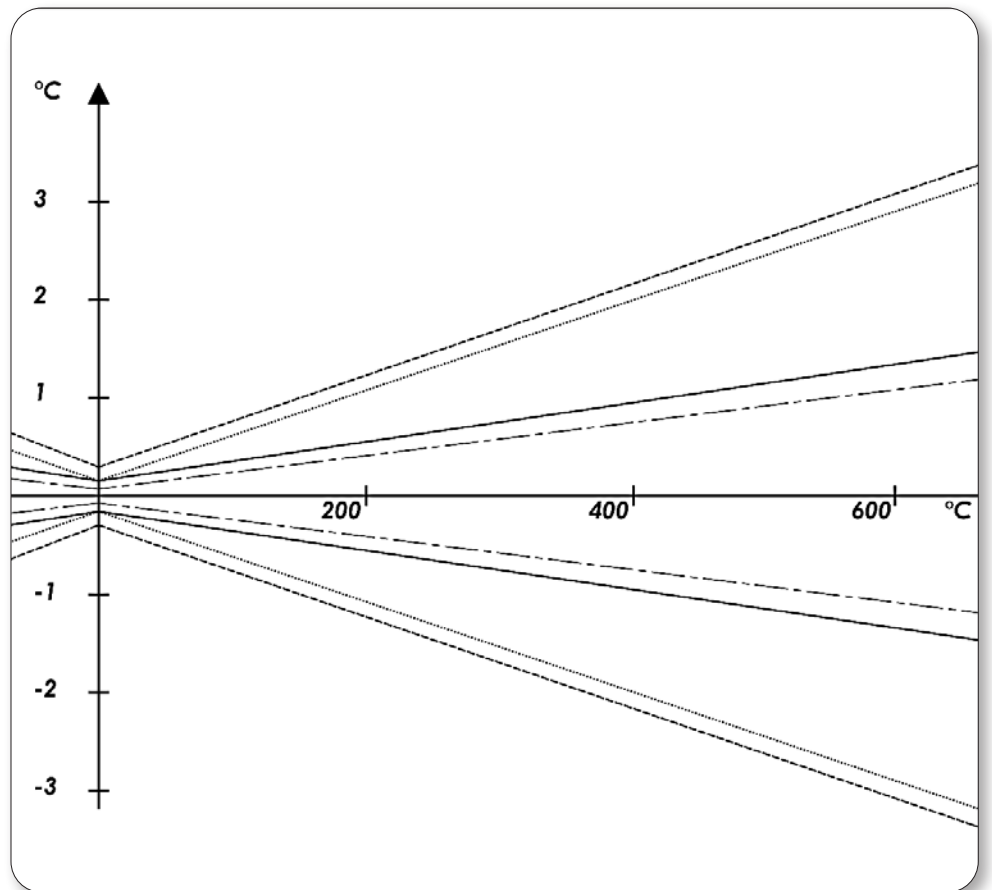

## Resistance data

Resistance values for the thermistors from -50°C to 600°C in 1°C steps. Resistance values in the chart have to be multiplied by factor 100 for PT100, by factor 500 for PT500, by factor 1000 for PT1000.

°C\°C	0	1	2	3	4	5	6	7	8	9
-50	0.803									
-40	0.843	0.839	0.835	0.831	0.827	0.823	0.819	0.815	0.811	0.807
-30	0.882	0.787	0.874	0.870	0.866	0.862	0.859	0.855	0.851	0.847
-20	0.922	0.918	0.914	0.910	0.906	0.902	0.898	0.894	0.890	0.866
-10	0.961	0.957	0.953	0.949	0.945	0.941	0.937	0.933	0.929	0.926
0	1.000	0.996	0.992	0.988	0.984	0.980	0.977	0.973	0.969	0.965
0	1.000	1.004	1.008	1.012	1.016	1.020	1.023	1.027	1.031	1.035
10	1.039	1.043	1.047	1.051	1.055	1.058	1.062	1.066	1.070	1.074
20	1.078	1.082	1.086	1.090	1.093	1.097	1.101	1.105	1.109	1.113
30	1.117	1.121	1.124	1.128	1.132	1.136	1.140	1.144	1.148	1.152
40	1.155	1.159	1.163	1.167	1.171	1.175	1.179	1.182	1.186	1.190
50	1.194	1.198	1.202	1.205	1.209	1.213	1.217	1.121	1.125	1.129
60	1.232	1.236	1.240	1.244	1.248	1.252	1.255	1.259	1.263	1.267
70	1.271	1.275	1.278	1.282	1.286	1.290	1.294	1.297	1.301	1.305
80	1.309	1.313	1.317	1.320	1.324	1.328	1.332	1.336	1.339	1.343
90	1.347	1.351	1.355	1.358	1.362	1.366	1.370	1.374	1.377	1.381
100	1.385	1.389	1.393	1.396	1.400	1.404	1.408	1.412	1.415	1.419
110	1.423	1.427	1.430	1.434	1.438	1.442	1.446	1.449	1.453	1.457
120	1.461	1.464	1.468	1.472	1.476	1.479	1.483	1.487	1.491	1.494
130	1.498	1.502	1.506	1.501	1.513	1.517	1.521	1.525	1.528	1.532
140	1.536	1.539	1.543	1.547	1.551	1.554	1.558	1.562	1.566	1.569
150	1.573	1.577	1.581	1.584	1.588	1.592	1.596	1.599	1.603	1.607
160	1.610	1.614	1.618	1.622	1.625	1.629	1.633	1.636	1.640	1.644
170	1.648	1.651	1.655	1.659	1.662	1.666	1.670	1.674	1.677	1.681
180	1.685	1.688	1.692	1.696	1.699	1.703	1.707	1.711	1.714	1.718
190	1.722	1.725	1.729	1.733	1.736	1.740	1.744	1.747	1.751	1.755
200	1.758	1.762	1.766	1.769	1.773	1.777	1.780	1.784	1.788	1.791
210	1.795	1.799	1.802	1.806	1.810	1.813	1.817	1.821	1.824	1.828
220	1.832	1.835	1.839	1.843	1.846	1.850	1.854	1.857	1.861	1.865
230	1.868	1.872	1.875	1.879	1.883	1.886	1.890	1.894	1.897	1.901
240	1.905	1.908	1.912	1.915	1.919	1.923	1.926	1.930	1.934	1.937
250	1.941	1.944	1.948	1.952	1.955	1.959	1.962	1.966	1.970	1.973
260	1.977	1.980	1.984	1.988	1.991	1.995	1.998	2.002	2.006	2.009
270	2.013	2.016	2.020	2.024	2.027	2.031	2.034	2.038	2.042	2.045
280	2.049	2.052	2.056	2.060	2.063	2.067	2.070	2.074	2.077	2.081
290	2.085	2.088	2.092	2.095	2.099	2.102	2.106	2.110	2.113	2.117
300	2.120	2.124	2.127	2.131	2.134	2.138	2.142	2.145	2.149	2.152
310	2.156	2.159	2.163	2.166	2.170	2.173	2.177	2.181	2.184	2.188
320	2.191	2.195	2.198	2.202	2.205	2.209	2.212	2.216	2.219	2.223
330	2.226	2.230	2.234	2.237	2.241	2.244	2.248	2.251	2.255	2.258
340	2.262	2.265	2.269	2.272	2.276	2.279	2.283	2.286	2.290	2.293
350	2.297	2.300	2.304	2.307	2.311	2.314	2.318	2.321	2.325	2.328
360	2.332	2.335	2.339	2.342	2.346	2.349	2.353	2.356	2.360	2.363
370	2.367	2.370	2.373	2.377	2.380	2.384	2.387	2.391	2.394	2.398
380	2.401	2.405	2.408	2.412	2.415	2.419	2.422	2.426	2.429	2.432
390	2.436	2.439	2.443	2.446	2.445	2.453	2.457	2.460	2.463	2.467
400	2.470	2.474	2.477	2.481	2.484	2.488	2.491	2.494	2.498	2.501
410	2.505	2.508	2.512	2.515	2.518	2.522	2.525	2.529	2.532	2.536
420	2.539	2.542	2.546	2.549	2.553	2.556	2.560	2.563	2.566	2.570
430	2.573	2.577	2.580	2.583	2.587	2.590	2.594	2.597	2.600	2.604
440	2.607	2.611	2.614	2.617	2.621	2.624	2.628	2.631	2.634	2.638
450	2.641	2.645	2.648	2.651	2.655	2.658	2.661	2.665	2.668	2.672
460	2.675	2.678	2.682	2.685	2.688	2.692	2.695	2.699	2.702	2.705
470	2.709	2.712	2.715	2.719	2.722	2.725	2.729	2.732	2.735	2.739
480	2.742	2.746	2.749	2.752	2.756	2.759	2.762	2.766	2.769	2.772
490	2.776	2.779	2.782	2.786	2.789	2.792	2.796	2.799	2.802	2.806
500	2.809	2.812	2.816	2.819	2.822	2.826	2.829	2.832	2.836	2.839
510	2.842	2.845	2.849	2.852	2.855	2.859	2.862	2.865	2.869	2.872
520	2.875	2.879	2.882	2.885	2.888	2.892	2.895	2.898	2.902	2.905
530	2.908	2.912	2.915	2.918	2.921	2.925	2.928	2.931	2.935	2.938
540	2.941	2.944	2.948	2.951	2.954	2.958	2.961	2.964	2.967	2.971
550	2.974	2.977	2.980	2.984	2.987	2.990	2.993	2.997	3.000	3.003
560	3.007	3.010	3.013	3.016	3.020	3.023	3.026	3.029	3.033	3.036
570	3.039	3.042	3.046	3.049	3.052	3.055	3.059	3.062	3.065	3.068
580	3.071	3.075	3.078	3.081	3.084	3.088	3.091	3.094	3.097	3.101
590	3.104	3.107	3.110	3.113	3.117	3.120	3.123	3.126	3.130	3.133
600	3.136									

PT-circuits according to the DIN EN 60751, 1 thermistor

2-wire circuit

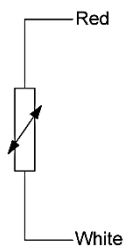

3-wire circuit

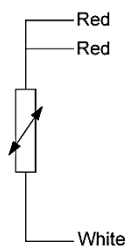

4-wire circuit

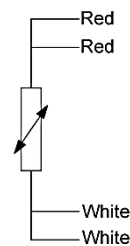

Examples of KTY-thermistor-housings

Shrink tube housing for monitoring windings

Shielded cable is optional

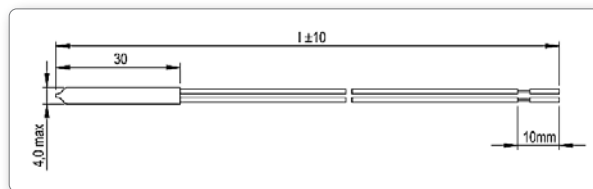

Screw-in sensors in alu-housing AL-M3/SW8 and AL-M4/SW10

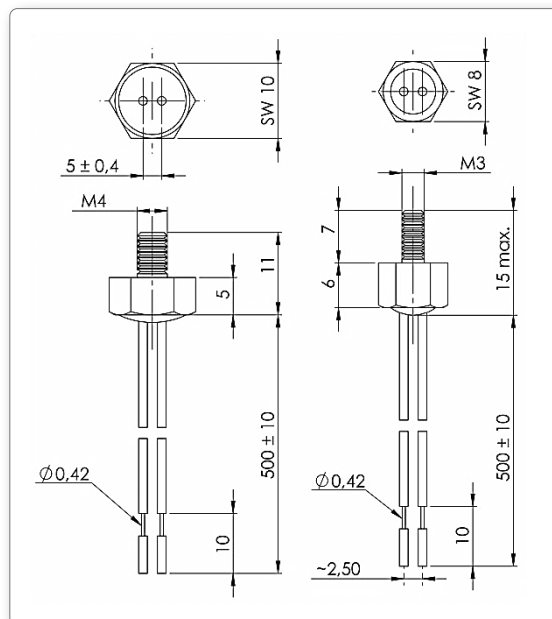

### PT-sensor in cable shoe surface

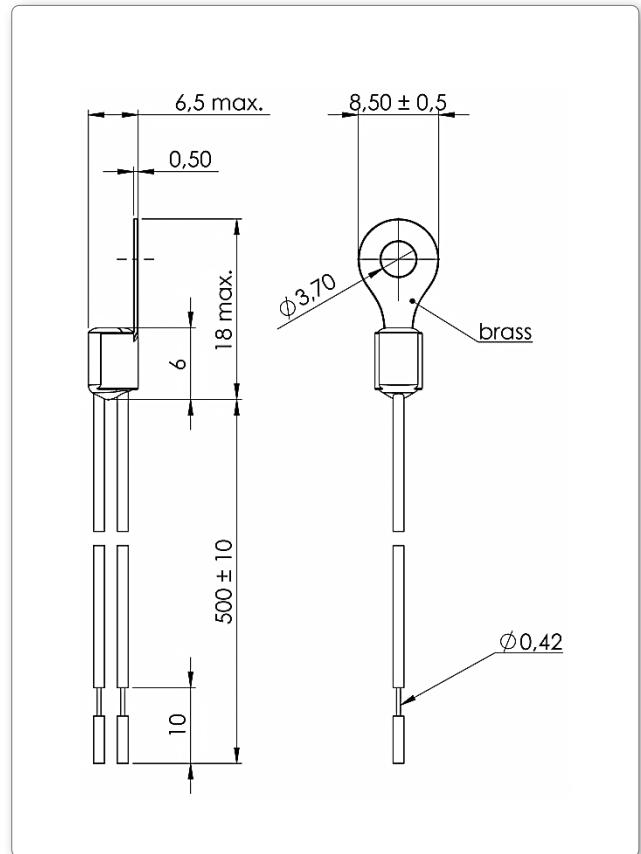

### PT-sensor in ceramics or brass-housing

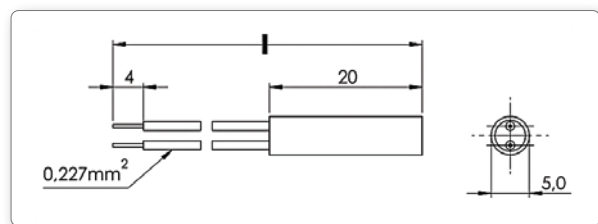

### PT-sensor in stainless steel

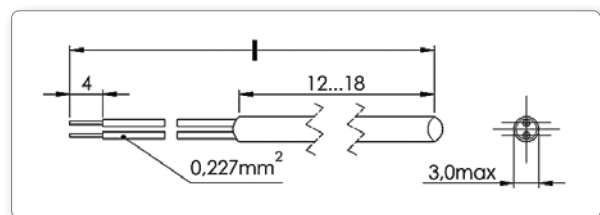

## Slot resistance sensors



## Platinum sensor probe

A platinum sensor probe can be specially made for liquid or gaseous media, in V2A or similar.



## Item list

Item no.	Description	Sensor, ca (mm)	Cable length, ca (mm)	Insulation (kV)	No. of wires	Core colour +/-	Outer material
112383	PT100 for winding	4.5	1 500	2.5	2	red/black	Heat shrinkable tubing
126003	PT100 for winding	4.5	1 500	2.5	3	red/black, black	Heat shrinkable tubing
126004	PT100 for winding	3.8	900	4	2	red/white	Heat shrinkable tubing
126005	PT100 for winding	3.8	5 350	4	2	red/white	Heat shrinkable tubing
126006	PT100 for winding	3.0 × 22 (Ø × L)*	2 000	2.5	2	red/white	Steel tube
126007	PT 100 for windings with slot resistance	250 × 8.5 × 2.5 (L × W × T)*	6 000	2.5	3	red, red/white	Fiber glass and Kapton film
126008	PT100 for winding	6.0 × 60 (Ø × L)*	6 000	2.5	3	white mantle and red, red/white	Steel tube
126015	PT100 for winding	Collar: 6.3 × 3.0 Stem: 4.75 × 9 (Ø × L)*	6 000	2.5	3	white mantle and red, red/white	Steel tube with collar
126011	PT100 for winding	4.6	4 000	2.5	4	red, red/black, black	Heat shrinkable tubing
126013	PT100 for winding	2.6	900	2.5	2, twined	red/white	Heat shrinkable tubing
126016	PT 100 for windings with slot resistance	2 × 5 × 150 (L × W × T)*	5 000	3.0	3	red, red/white	Fiber glass with shrink hose
126480	PT100 for winding	4.5	2 000	2.5	2, twined	red/white	Heat shrinkable tubing
126517	PT1000 for winding	4.5	500	2.5	3	red, red/white	Heat shrinkable tubing

Special versions are available on request.

\* L = Length  
W = Width  
T = Thickness

### How to contact BEVI

Contact details for all countries are continually updated on our website.  
Please visit [www.bevi.com](http://www.bevi.com) to access the information direct.

BEVI AB (Headquarters)  
Blomstermåla, Sweden  
Tel. +46 499 271 00  
[info@bevi.se](mailto:info@bevi.se)

