



## SLIP RINGS

Slip rings in the standard version are manufactured in phosphor bronze Grade PB1 acc. BS 1400.

GZ - Cu Sn7 Zn Pb DIN 1705. Copper or copper nickel are as shown in the table below.

Insulation of DMC, reinforced with polyester-based glassfiber.

We also offer repairs of larger motor slip rings.

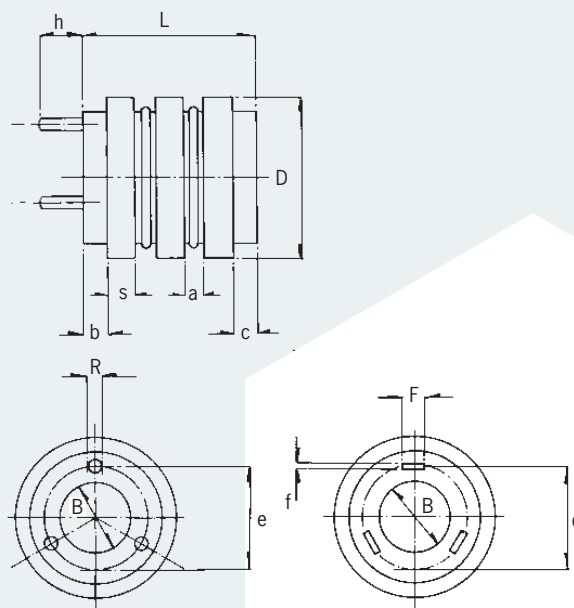

The table lists the most common types of slip rings we usually stock for immediate delivery

ITEM NUMBER	PRODUCT TYPE	NUMBER RINGS	D.	S.	STANDARD-HOLE Ø	MAX Ø BORE	L.	a.	b.	c.	e.	R.	Fxf	h
14 010 0252	2-52-10-25,4	2	52	10	25,4	28	30	7	2	1	40	-	5x1	7
14 010 0260	2-60-10-25	2	60	10	25	28	44	6,8	6,8	10	47	M5, M6	-	10
14 010 0270	2-70-10-31,75	2	70	10	31,75	33	36	6	6	5	48	4Ø	10x1	12
14 010 2102	2-102-12,7-25	2	102	12,7	25	48	52,4	12,7	8	6,3	73	M6	-	16
14 010 0340	3-40-9,5-19	3	40	9,5	19	20	38	3	1,75	1,75	27	-	5x1	10
14 010 0352	3-52-10-25,4	3	52	10	25,4	28	52	7	7	1	40	-	5x1	7
14 010 0360	3-60-10-25	3	60	10	25	30	61	7	7	10	48	M5	-	15
14 010 0370	3-70-10-35	3	70	10	35	33	53,2	6	6	4,5	48	M5, M6	-	15
14 010 0380	3-80-12-38,1	3	80	12	38,1	45	69,5	12,4	4	4	47	M5	-	15
14 010 3100	3-100-14,3-45	3	100	14,3	45	54	74,9	9,5	7,3	5,3	72	M8	-	15
14 021 3115	3-115-20-45-57	3	115	20	45-57	-	112	15	-	-	85	M8	-	25
14 010 3120	3-120-12,7-58**	3	120	12,7	58	73	76,3	12	6,5	6	-	M8	-	18
14 010 3127	3-127-19-34,9	3	127	19	34,9	83	89,3	9,5	7,8	4,6	96	M6, M8	-	15
14 010 0452	4-52-10-25,4	4	52	10	25,4	26	64	7	1	1	40	-	5x1	14
14 010 0460	4-60-10-25	4	60	10	25	28	78,5	7	6	11,5	40	M5	-	15
14 010 0470	4-70-10-34,8	4	70	10	34,8	36	68	6	5	4,5	48	4Ø	10x1	12
14 010 0860	8-60-10-25*	8	60	10	25	25	158	7	4	12	40	M5	-	10

\* Copper rings \*\* Copper nickel rings

Slip rings not shown in the table can be manufactured. Request price details.

*Product information for which Carbex bears no responsibility is provided by the manufacturer.*